



CHANGE[®]

Foundations & Installing Tools for Transmission & Substations

Catalog 4B May 2023



DISCLAIMER

The information in this manual is provided as a guide to assist you with your design and in writing your own specifications. Installation conditions, including soil and structure conditions, vary widely from location to location and from point to point on a site.

Independent engineering analysis and consulting state and local building codes and authorities should be conducted prior to any installation to ascertain and verify compliance to relevant rules, regulations and requirements.

Hubbell, Inc., shall not be responsible for, or liable to you and/or your customers for the adoption, revision, implementation, use or misuse of this information. Hubbell, Inc., takes great pride and has every confidence in its network of dealers/installing contractors. Hubbell, Inc., does NOT warrant the work of its dealers/installing contractors in the installation of CHANCE® Civil Construction foundation support products.

TABLE OF CONTENTS

SECTION DESCRIPTION	PAGE
Square Shaft (SS) Products	
Introduction to Round and Square Shaft	4B-4
Square Shaft (SS) Product Ratings, Section Properties and Mechanical Strength	4B-5 - 6
1½" Round Corner Square Shaft (SS5 Series)	4B-7
1½" Round Corner Square Shaft (SS150 Series)	4B-8
1¾" Round Corner Square Shaft (SS175 Series)	4B-9
2" Round Corner Square Shaft (SS200 Series)	4B-10
2¼" Round Corner Square Shaft (SS225 Series)	4B-11
Notes: 1¼" to 2¼" Square Bar Products	4B-12
CHANCE® Helical Pulldown® Micropiles, Displacement Plates	4B-13 - 14
Round Shaft (RS) Products	
Catalog Numbering System for Helical Round Shaft Foundations	4B-15
Round Shaft (RS) Product Ratings, Section Properties and Mechanical Strength	4B-16 - 17
2⅞" Round Shaft (RS2875.203 Series)	4B-18
2⅞" Round Shaft (RS2875.276 Series)	4B-19
3½" Round Shaft (RS3500.300 Series)	4B-20
4½" Round Shaft (RS4500.337 Series)	4B-21
6⅝" Round Shaft (RS6625.280 Series)	4B-22
8⅝" Round Shaft (RS8625.250 Series)	4B-23
Notes: 2⅞" to 8⅝" OD Round (Pipe) Shaft Products	4B-24
Square Shaft & Round Shaft (SS/RS) Combinations	4B-25
Assemblies and Hardware	
CHANCE® Helical New Construction Pile and Rebar Caps	4B-26
Grillages	4B-27
Installation Tools	4B-28 - 31

Square Shaft

Round Shaft

SS/RS Combos

Hardware

Installing Tools



CHANCE[®] HELICAL ANCHORS/PILES

Square Shaft

INTRODUCTION

A helical anchor/pile is a segmented deep foundation system with helical bearing plates welded to a central steel shaft. Load is transferred from the shaft to the soil through these bearing plates. Central steel shafts are available in either Type SS (Square Shaft) series or Type RS (Round Shaft) series. The Type SS series are available in 1½" to 2¼" square sizes. The Type RS series are available in 2⅞" to 8⅝" diameter sizes. Type SS-RS combinations are also available for compression applications in soil conditions where dense/hard soils must be penetrated with softer/loose soils above the bearing strata. The Helical Pulldown[®] Micropile series is also used in applications similar to those requiring the use of the Type SS-RS combinations.

Segments or sections are joined with bolted couplings. Installation depth is limited only by soil density and practicality based on economics. A helical bearing plate or helix is one pitch of a screw thread. All helices, regardless of their diameter, have a standard 3" pitch. Being a true helical shape, the helices do not auger into the soil but rather screw into it with minimal soil disturbance. Helical plates are spaced at distances far enough apart that they function independently as individual bearing elements; consequently, the capacity of a particular helix on a helical anchor/pile shaft is not influenced by the helix above or below it.

Lead Section and Extensions

The first section or lead section contains the helical plates. This lead section can consist of a single helix or up to four helices. Additional helices can be added, if required, with the use of helical extensions. Standard helix sizes are shown in Table 1. The helices are arranged on the shaft such that their diameters increase as they get farther from the pilot point. The practical limits on the number of helices per anchor/pile is four to five if placed in a cohesive soil and six if placed in a cohesionless or granular soil.

Plain extensions are then added in standard lengths of 3, 5, 7 and 10 feet until the lead section penetrates into the bearing strata. Standard helix configurations are provided in the product series tables in this section. Note that lead time will be significantly reduced if a standard helix configuration is selected.

STANDARD HELIX SIZES

Table 1

LEAD SECTION AND EXTENSIONS	
DIAMETER in (cm)	AREA ft ² (m ²)
6 (15)	0.185 (0.0172)
8 (20)	0.336 (0.0312)
10 (25)	0.531 (0.0493)
12 (30)	0.771 (0.0716)
14 (35)	1.049 (0.0974)
16 (40)	1.385 (0.1286)



CHANCE® HELICAL ROUND CORNER SQUARE SHAFT PRODUCTS

CHANCE® Square Shaft (SS) Helical Product Ratings

Table 2

Product Series	Torque Rating ft-lbs (Nm)	Ultimate Tension Strength* kip (kN)	Uplift/Compression Capacity Limit** kip (kN)
SS5	5,700 (7 700)	70 (312)	55 (245)
SS150	7,000 (9 500)	70 (312)	70 (312)
SS175	11,000 (14 900)	100 (445)	110 (489)
SS200	16,000 (21 700)	150 (668)	150 (668) ***
SS225	21,000 (28 475)	200 (890)	200 (890) ***

* Based on Mechanical Strength of Coupling

** Based on Torque Rating – Uplift/Compression Capacity Limit = Torque Rating x Kt.

“Default” Kt for Type SS = 10 ft-1 (33 m-1)

*** Based on Mechanical Strength of Coupling Bolt

Higher Compression Capacities Available with Helical Pulldown® Micropile

CHANCE® Square Shaft Helical Cross Sections

Figure 1

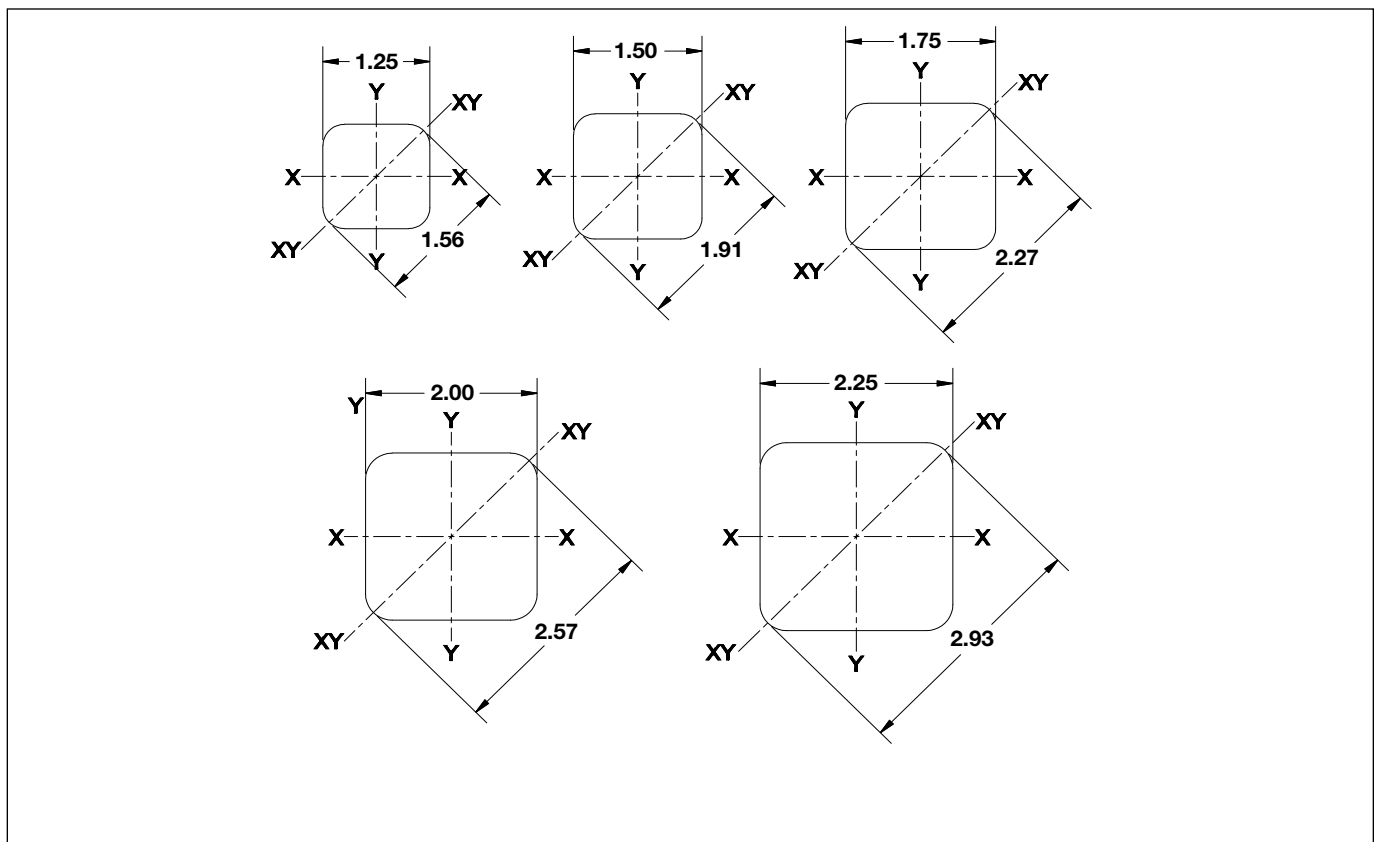

CHANCE® Square Shaft (SS) Helical Section Properties

Table 3

Product Series	Shaft Size in (mm)	Wall Thickness in (mm)	Metal Area in ² (cm ²)	Perimeter in (cm)	Moment of Inertia in ⁴ (cm ⁴) <i>I_{x-x}, I_{y-y}, I_{x-y}</i>	Section Modulus in ³ (cm ³)	
						<i>S_{x-x}</i>	<i>S_{y-y}</i>
SS5	1.5 (38)	solid	2.2 (14.2)	5.6 (14.2)	0.40 (16.5)	0.53 (8.7)	0.42 (6.9)
SS150	1.5 (38)	solid	2.2 (14.2)	5.6 (14.2)	0.40 (16.5)	0.53 (8.7)	0.42 (6.9)
SS175	1.75 (44)	solid	3.1 (19.4)	6.6 (16.7)	0.75 (31.1)	0.85 (13.9)	0.66 (10.8)
SS200	2 (51)	solid	3.9 (25.3)	7.5 (18.9)	1.26 (52.4)	1.26 (20.6)	0.98 (16.1)
SS225	2.25 (57)	solid	5.0 (32.1)	8.5 (21.5)	2.04 (84.9)	1.81 (29.7)	1.40 (22.9)

CHANCE® Square Shaft (SS) Helix Thickness and Mechanical Strength

Table 4

DEFAULT (STANDARD)				OPTIONS		
Product Series	Helix Grade ksi (mPa)	Thickness in (mm)	Mechanical Strength kip (kN)	Helix Grade ksi (mPa)	Thickness in (mm)	Mechanical Strength kip (kN)
SS5	50 (345)	3/8" (9.5)	40 (178)	50 (345)	1/2" (13)	45 (200)
				80 (552)	3/8" (9.5)	40 (178)
				80 (552)	1/2" (13)	50 (222)
SS150	80 (552)	3/8" (9.5)	40 (178)	50 (345)	1/2" (13)	45 (200)
SS175	80 (552)	3/8" (9.5)	50 (222)	80 (552)	1/2" (13)	60 (267)
SS200	80 (552)	1/2" (13)	60 (267)	---	---	---
SS225	80 (552)	1/2" (13)	60 (267)	---	---	---

The mechanical strength ratings in Table 4 are minimum values. The helix diameter, grade, and thickness along with the shaft series to which an individual helix is connected effect the mechanical strength rating of a helix. A higher mechanical strength rating of an individual helix is possible depending on the combination of these variables.

CHANCE® HELICAL 1¹/₂" ROUND CORNER SQUARE SHAFT PRODUCTS (TYPE SS5 SERIES)

COMMON LEAD CONFIGURATIONS

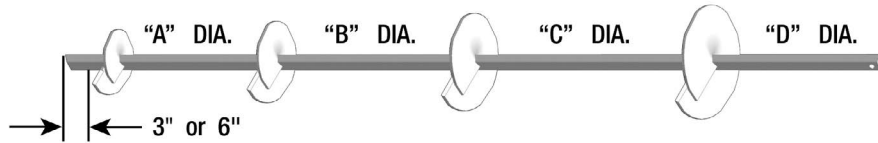

Square Shaft

Catalog Number (See Notes Page 12)	Plate Diameter				Nominal Length (ft)	Effective Length (in)*	Weight (lbs)	Helix Grade
	A	B	C	D				
T1100676	6	8	-	-	3	29.7	50	50
012642AE	8	10	-	-	3	32.7	39	50
012642AEJ	8	10	12	-	5.5	60.2	67	50
012642AEJN	8	10	12	14	10	116.9	109	50
T1100677	10	-	-	-	7	76.2	62	50
012642EJ	10	12	-	-	3.5	38.9	55	50
012642EJN	10	12	14	-	7	76.2	63	50
012642EJNS	10	12	14	14	10.5	116.9	131	50

*Effective length: from leading edge of bottom helix to center of bolt hole.

"T" after plate diameter means 1/2" thick helix.

CHANCE® HELICAL 1¹/₂" ROUND CORNER SQUARE SHAFT PRODUCTS (TYPE SS5 SERIES)

COMMON EXTENSION CONFIGURATIONS

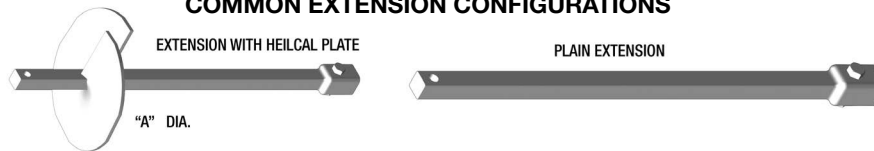

Plain Extension

Catalog Number (See Notes Page 12)	Plate Diameter		Nominal Length (ft)	Effective Length (in)*	Weight (lbs)	Helix Grade	Coating
	A	B					
12655	-	-	3.5	37.4	28	---	GALV
12656	-	-	5	57.2	40	---	GALV
12657	-	-	7	80.2	57	---	GALV
12658	-	-	10	119.7	78	---	GALV
12655J	12	-	5	57.2	54	50	GALV
12656N	14	-	5	57.2	60	50	GALV

* Effective length: from bolt hole to bolt hole.

CHANCE® HELICAL 1½" ROUND CORNER SQUARE SHAFT PRODUCTS (TYPE SS150 SERIES)

Square Shaft

COMMON LEAD CONFIGURATIONS

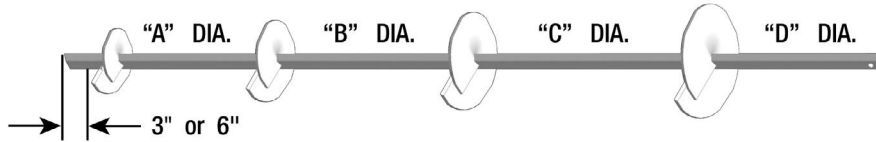

Catalog Number (See Notes Page 12)	Plate Diameter				Nominal Length (ft)	Effective Length (in)*	Weight (lbs)	Helix Grade
	A	B	C	D				
T1100513	4	8	10	-	5	57.2	58	36
C1100385	8	10	-	-	3	29.7	39	80
C1100386	8	10	12	-	5	60.2	70	80
T1100521	8	10	12	14	10	116.9	127	80
T1100631	10	12	14	-	7	76.2	96	80
C1100504	14	14	14	-	10	116.9	135	80

*Effective length: from leading edge of bottom helix to center of bolt hole.

COMMON EXTENSION CONFIGURATIONS

EXTENSION WITH HELICAL PLATE

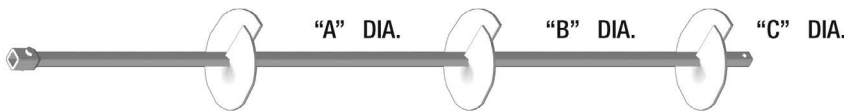

PLAIN EXTENSION



Catalog Number (See Notes Page 12)	Plate Diameter			Nominal Length (ft)	Effective Length (in)*	Weight (lbs)	Helix Grade
	A	B	C				
C1100388	-	-	-	3.5	37.4	27	---
C1100470	-	-	-	5	57.2	41	---
C1100389	-	-	-	7	80.2	54	---
C1100440	-	-	-	10	127.2	81	---
C1100471	14	-	-	4	44.9	28	80
C1100454	14	14	-	7	80.2	93	80
C1100475	14	14	14	10	122.2	142	80

* Effective length: from bolt hole to bolt hole.



CHANCE[®] HELICAL 1³/₄" ROUND CORNER SQUARE SHAFT PRODUCTS (TYPE SS175 SERIES)

COMMON LEAD CONFIGURATIONS

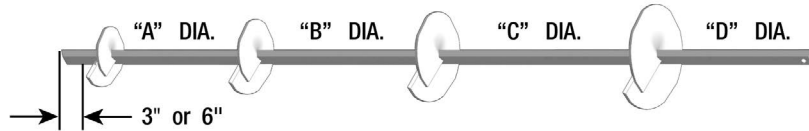

Catalog Number (See Notes Page 12)	Plate Diameter				Nominal Length (ft)	Effective Length (in)*	Weight (lbs)	Helix Grade
	A	B	C	D				
C1100227	8	10	-	-	3.5	30.1	51	80
C1100235	8	10	12	-	5	57.8	82	80
C1100884	10	12	-	-	5	57.8	80	80
C1100505	14	14	14	-	10	122.3	158	80
T1100730	14	14	-	-	7	76.3	114	80

*Effective length: from leading edge of bottom helix to center of bolt hole.

CHANCE[®] HELICAL 1³/₄" ROUND CORNER SQUARE SHAFT PRODUCTS (TYPE SS175 SERIES)

COMMON EXTENSION CONFIGURATIONS

EXTENSION WITH HELICAL PLATE

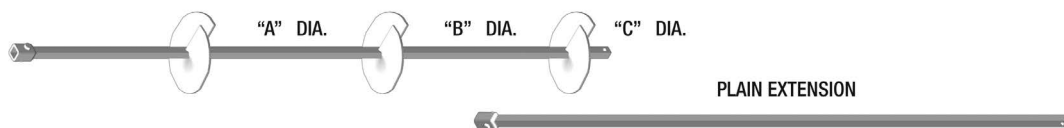

Catalog Number (See Notes Page 12)	Plate Diameter			Nominal Length (ft)	Effective Length (in)*	Weight (lbs)	Helix Grade
	A	B	C				
C1100136	-	-	-	3.5	36.8	35	---
C1100137	-	-	-	5	58.3	56	---
C1100138	-	-	-	7	79.8	76	---
C1100140	-	-	-	10	123.1	112	---
C1100472	14	-	-	4	45.6	66	80
C1100450	14	14	-	7	79.8	116	80
C1100476	14	14	14	10	123.1	168	80

* Effective length: from bolt hole to bolt hole.

CHANCE[®] HELICAL 2" ROUND CORNER SQUARE SHAFT PRODUCTS (TYPE SS200 SERIES)

COMMON LEAD CONFIGURATIONS

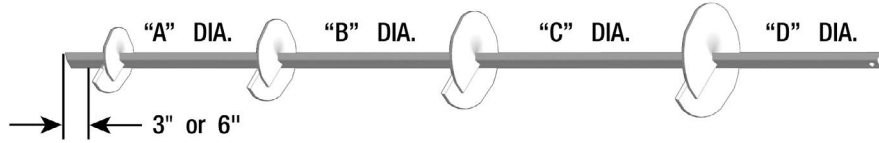

Catalog Number (See Notes Page 12)	Plate Diameter				Nominal Length (ft)	Effective Length (in)*	Weight (lbs)	Helix Grade
	A	B	C	D				
C1100569	6T	8T	10T	-	5	59.2	97	80
C1100571	6T	8T	10T	12T	7	78.9	136	80
C1100570	8T	10T	12T	-	5	59.2	120	80
C1100573	8T	10T	12T	14T	10	125.2	213	80
C1100572	14T	14T	14T	-	10	125.2	228	80

*Effective length: from leading edge of bottom helix to center of bolt hole.

"T" after plate diameter means 1/2" thick helix.

COMMON EXTENSION CONFIGURATIONS

EXTENSION WITH HELICAL PLATE

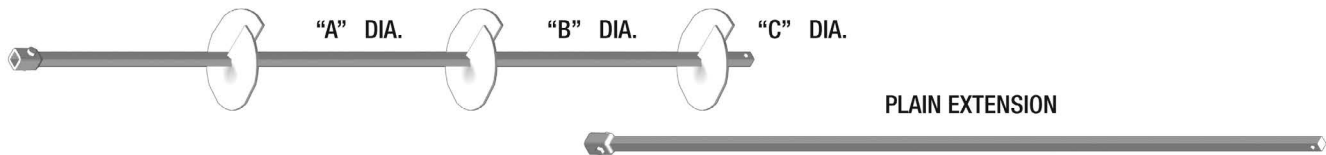

Catalog Number (See Notes Page 12)	Plate Diameter			Nominal Length (ft)	Effective Length (in)*	Weight (lbs)	Helix Grade
	A	B	C				
C1100563	-	-	-	3	36.6	50	---
C1100564	-	-	-	5	58.6	75	---
C1100565	-	-	-	7	80.1	100	---
C1100566	-	-	-	10	123.2	150	---
C1100577	14T	-	-	3	45.6	78	80
C1100581	14T	14T	-	7	80.1	152	80
C1100586	14T	14T	14T	10	123.1	225	80

* Effective length: from bolt hole to bolt hole.

"T" after plate diameter means 1/2" thick helix.



CHANCE® HELICAL 2¼" ROUND CORNER SQUARE SHAFT PRODUCTS (TYPE SS225 SERIES)

Square Shaft

COMMON LEAD CONFIGURATIONS

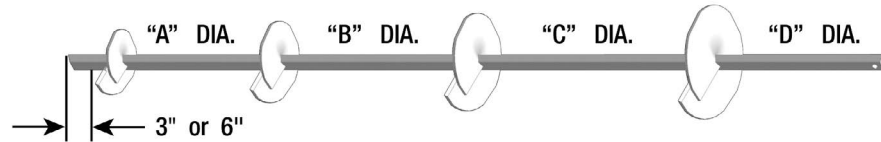

Catalog Number (See Notes Page 12)	Plate Diameter				Nominal Length (ft)	Effective Length (in)*	Weight (lbs)	Helix Grade
	A	B	C	D				
C1100543	6T	8T	10T	-	5	52.3	108	80
C1100544	8T	10T	12T	-	7	72.5	146	80
C1100591	8T	10T	12T	14T	10	112.8	142	80
C1100545	14T	14T	14T	-	10	142.8	250	80

*Effective length: from leading edge of bottom helix to center of bolt hole.

"T" after plate diameter means ½" thick helix.

COMMON EXTENSION CONFIGURATIONS

EXTENSION WITH HELICAL PLATE



PLAIN EXTENSION



Catalog Number (See Notes Page 12)	Plate Diameter			Nominal Length (ft)	Effective Length (in)*	Weight (lbs)	Helix Grade
	A	B	C				
C1100646	-	-	-	5	52.1	88	---
C1100647	-	-	-	7	72.1	116	---
C1100650	14T	-	-	5	52.1	79	80
C1100652	14T	14T	-	7	72.1	170	80

* Effective length: from bolt hole to bolt hole.

"T" after plate diameter means ½" thick helix.

NOTES: 1½" to 2¼" SQUARE BAR PRODUCTS

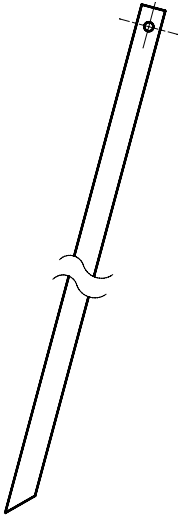

1. Included Connection Hardware:
SS5 and SS150 1½" Material: ¾" diameter bolt per ASTM A325 Type 1 and nut.
SS175 1¾" Material: 7/8" diameter bolt per ASTM A193 Grade B7 and nut.
SS200 2" Material: 1" diameter bolt per ASTM A193 Grade B7 and nut.
SS225 2¼" Material: 1¼" diameter bolt per ASTM A193 Grade B7 and nut.
2. The letter "T" after the helix diameter stands for ½" thick helix material.
3. All helices are spaced 3 times the diameter of the preceding helix unless otherwise specified by the customer.
4. The standard helix has a sharpened leading edge.
5. All products are hot dip galvanized per ASTM A153.

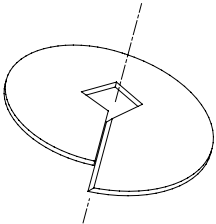

HELICAL PULLDOWN[®] MICROPILES

The Helical Pulldown[®] Micropile is a method used to form a grout column around the shaft of a standard helical anchor/pile. The installation process can employ grout only (see Figure 2) or grout in combination with either steel or PVC casing (see Figure 3).

To begin the process, a helical anchor/pile is placed into the soil by applying torque to the shaft. The helical shape of the bearing plates creates a significant downward force that keeps the foundation advancing into the soil. After the Lead Section with the helical plates penetrates the soil, a Lead Displacement Plate and Extension are placed onto the shaft. Resuming torque on the assembly advances the helical plates and pulls the displacement plate downward, forcing soil outward to create a cylindrical void around the shaft. From a reservoir at the surface, a flowable grout immediately fills this void surrounding the shaft. Additional extensions and displacement plates are added until the helical bearing plates reach the minimum depth required or competent load-bearing soil. This displacement pile system does not require removing spoils from the site.

Uncased Helical Pulldown[®] Micropile

Figure 2

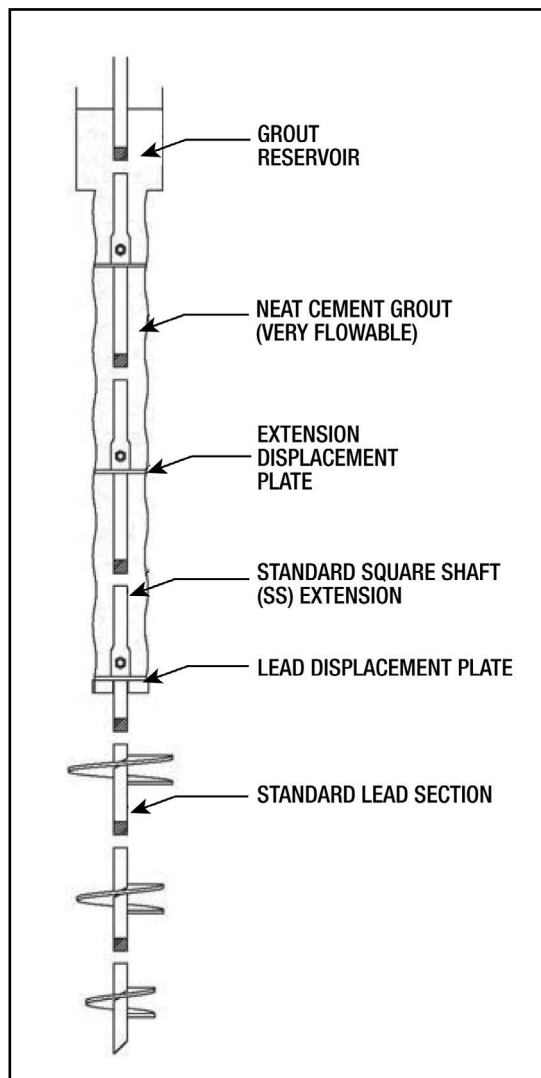

Cased Helical Pulldown[®] Micropile

Figure 3

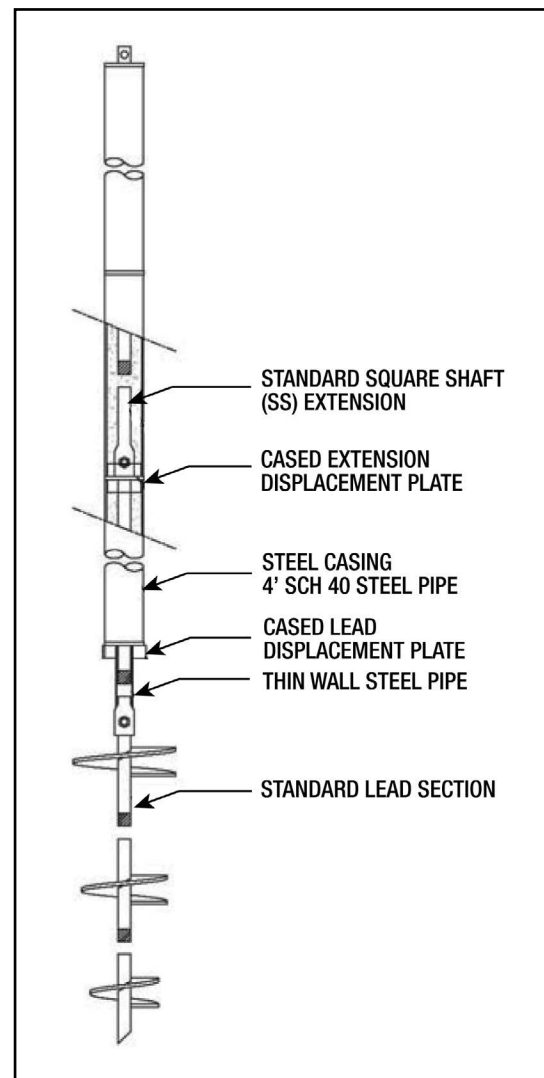

Square Shaft

Displacement Plates for Cased Grout Columns

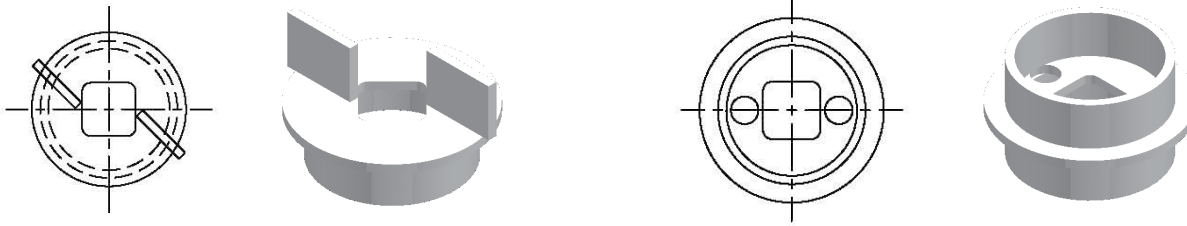

Lead Displacement Plates

Catalog Number	Plate Dia (in)	Casing Dia (in)	Product Series
T1100911	5	4	SS5/SS150
C1100912	7	6	SS175

Extension Displacement Plates

Catalog Number	Plate Dia (in)	Casing Dia (in)	Product Series
T1100913	5	4	SS5/SS150
C1100914	7	6	SS175

Displacement Plates for Uncased Grout Columns



Lead Displacement Plates

Catalog Number	Plate Dia (in)	Product Series
T1100915	5	SS5/SS150
C1100916	5	SS175

Extension Displacement Plates

Catalog Number	Plate Dia (in)	Helical Connection
T1100917	5	SS5/SS150
C1100918	5	SS175

COMMON LEAD CONFIGURATIONS

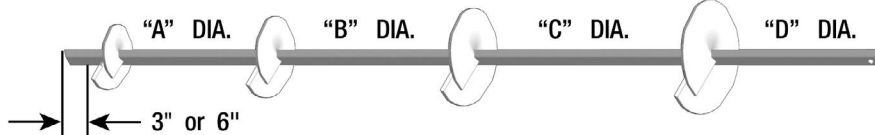

CHANCE[®] Helical Round-Cornered Square Shaft Leads used with HELICAL PULLDOWN[®] Micropile ⁽¹⁾

Type	Catalog Number	Helix Plate Diameter (in)				Nominal Length (ft)	Effective Length (in)	Weight (lb)	Helix Grade
		A	B	C	D				
SS5	C1100921	8	10	12	-	7	76.2	79	50
SS175	C1100922	8	10	12	-	7	76.2	100	50

⁽¹⁾ HELICAL PULLDOWN[®] Micropiles use Standard Extensions.

Helical Round Shaft Foundations Catalog Numbering System

NOTICE: CHANCE[®] can custom design a helical foundation for given loads and soil conditions, and is not limited to the options shown below. For more information, please contact your Hubbell Power Systems representative.

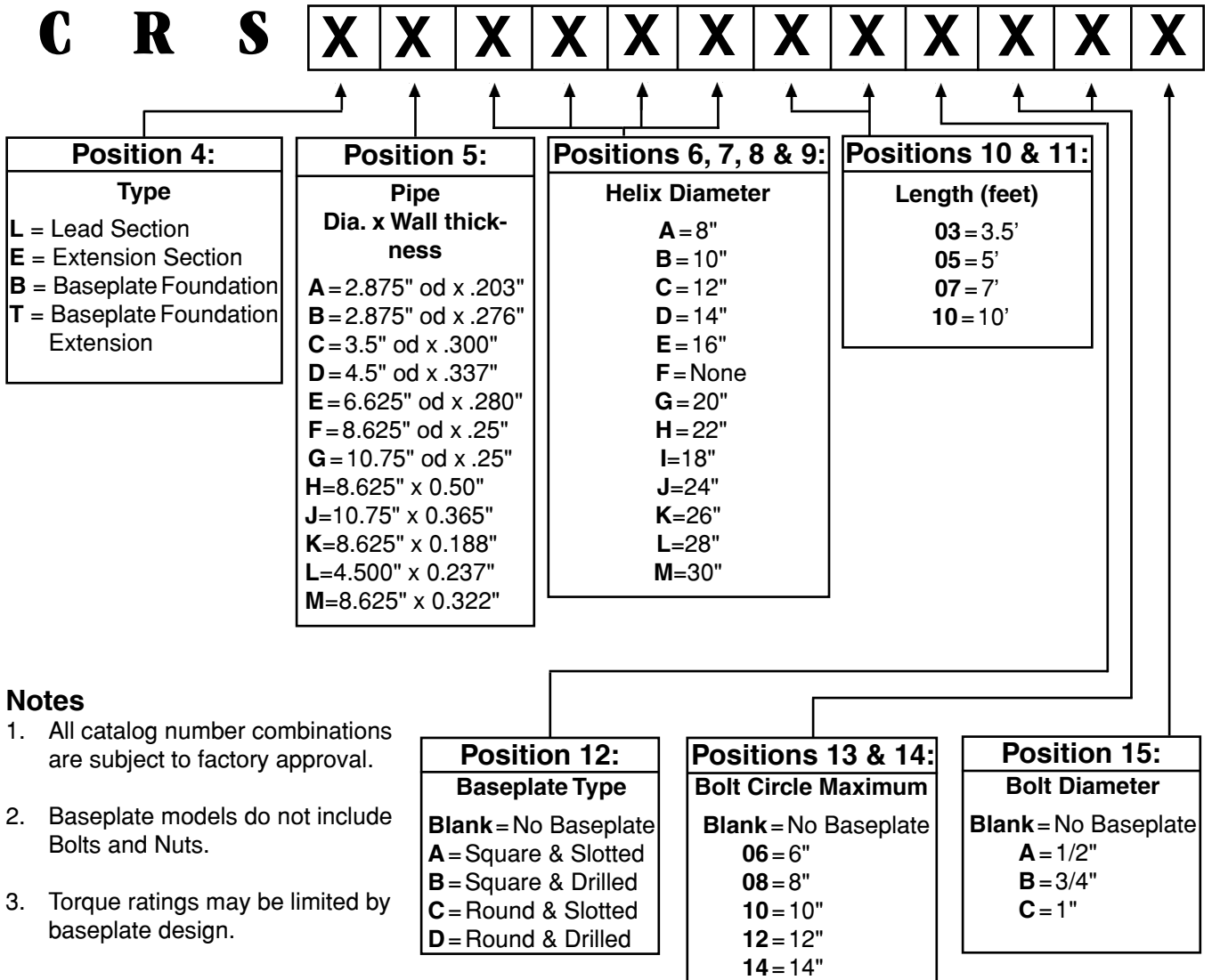

Round Shaft

Example:

CRSBEFFFF10B08B = Baseplate Foundation with Helix:
on Pipe Shaft of 6.625" Diameter with .280" Wall thickness; 1 Helix of 12" Diameter; 10 feet Long;
Square & Drilled Baseplate with 8" Maximum Bolt Circle for use with 3/4" Bolts.

CHANCE[®] HELICAL ROUND SHAFT PRODUCTS

CHANCE[®] Round Shaft (RS) Helical Product Ratings

Table 5

Product Series	Torque Rating ft-lbs (Nm)	Ultimate Tension Strength* kip (kN)	Uplift/Compression Capacity Limit** kip (kN)
RS2875.203	7,000 (9 491)	60 (267)	49.5 (220)
RS2875.276	8,000 (10 846)	90 (400)	72 (320)
RS3500.300	13,000 (17 600)	120 (534)	91 (405)
RS4500.337	25,000 (33 900)	140 (623)	138 (614)
RS6625.280	40,000 (54 233)	200 (890)	200 (890)
RS8625.250	60,000 (81 349)	300 (1 334)	300 (1 334)

* Based on Mechanical Strength of Coupling

** Based on Torque Rating – Uplift/Compression Capacity Limit = Torque Rating x K_t

"Default" K_t for Type RS2875 Series = 9 ft^{-1} (30 m^{-1}); for Type RS3500.300 = 7 ft^{-1} (23 m^{-1});

for Type RS4500.337 = 6 ft^{-1} (20 m^{-1});

for Type RS6625.280 = 5 ft^{-1} (13 m^{-1});

for Type RS8624.250 = 4 ft^{-1} (13 m^{-1});

CHANCE[®] Round Shaft Helical Cross Sections

Figure 4

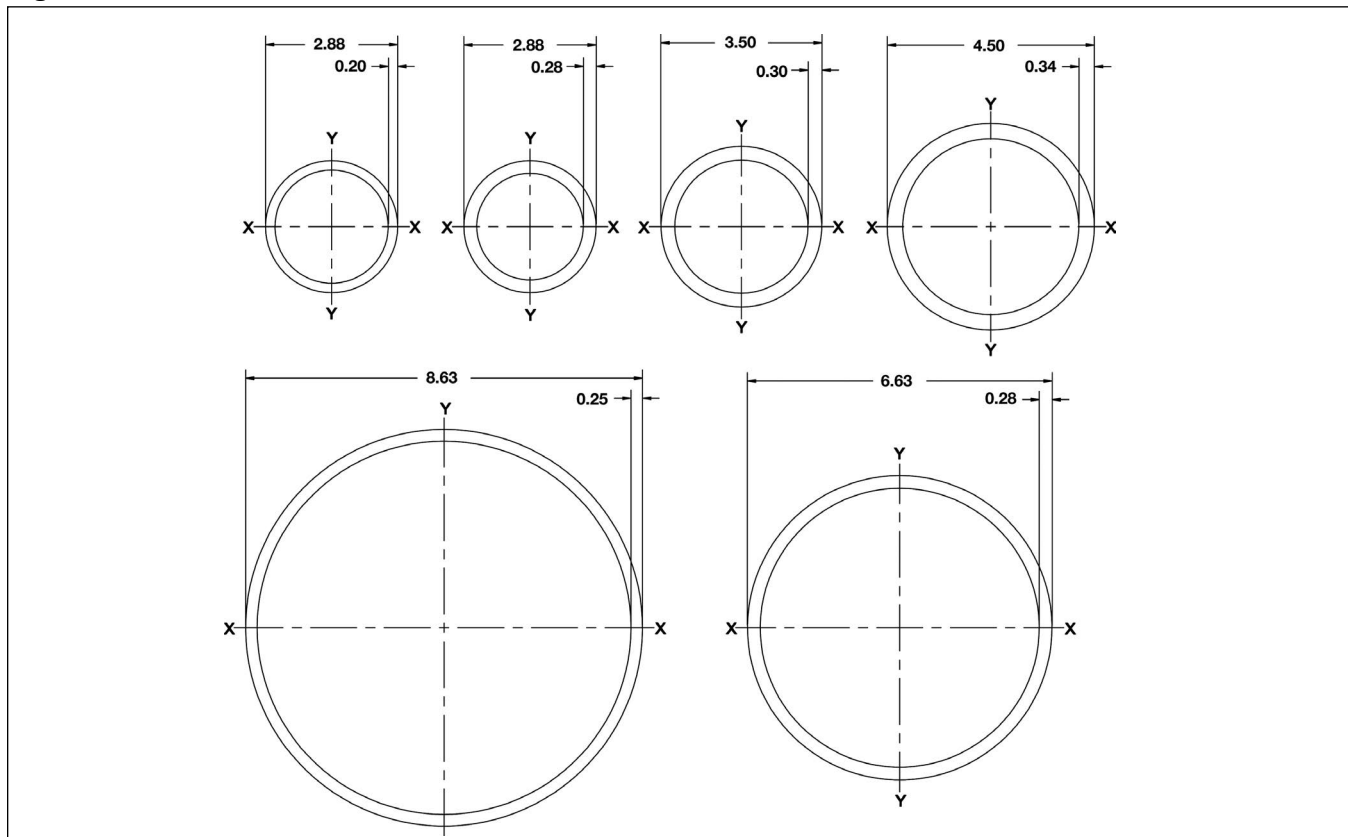

CHANCE® Round Shaft (RS) Helical Section Properties

Table 6

Product Series	Shaft Size in (mm)	Wall Thickness in (mm)	Metal Area in ² (cm ²)	Perimeter in (cm)	Moment of Inertia in ⁴ (cm ⁴) <i>I_{x-x}, I_{y-y}, I_{x-y}</i>	Section Modulus in ³ (cm ³)	
						<i>S_{x-x}</i> <i>S_{y-y}</i>	<i>S_{x-y}</i>
RS2875.203	2.875(73)	0.203 (5.2)	1.7 (11.0)	9.0 (22.9)	1.53 (63.7)	1.06 (17.4)	1.06 (17.4)
RS2875.276	2.875 (73)	0.276 (7.0)	2.3 (14.8)	9.0 (22.9)	1.92 (79.4)	1.34 (22.0)	1.34 (22.0)
RS3500.300	3.5 (89)	0.300 (7.6)	3.0 (19.5)	11.0 (27.9)	3.89 (162)	2.23 (36.5)	2.23 (36.5)
RS4500.337	4.5 (114)	0.337 (8.6)	4.4 (28.4)	14.1 (35.9)	9.61 (400.0)	4.27 (70.0)	4.27 (70.0)
RS6625.280	6.625 (168)	0.28 (7)	5.58 (36.0)	20.8 (52.8)	28.1 (1,168)	8.5 (139)	8.5 (139)
RS8625.250	8.625 (219)	0.25 (6)	6.58 (42.5)	27.1 (68.8)	57.7 (2,400)	13.38 (219)	13.38 (219)

CHANCE® Round Shaft (RS) Helix Thickness and Mechanical Strength

Table 7

DEFAULT (STANDARD)				OPTIONS		
Product Series	Helix Grade ksi (mPa)	Thickness in (mm)	Mechanical Strength kip (kN)	Helix Grade ksi (mPa)	Thickness in (mm)	Mechanical Strength kip (kN)
RS2875.203	50 (345)	⅜ (9.5)	40 (178)	50 (345)	½ (13)	50 (222)
RS2875.276	80 (552)	⅜ (9.5)	60 (267)	50 (345)	½ (13)	50 (222)
RS3500.300	50 (345)	½ (13)	60 (267)	50 (345)	⅜ (9.5)	50 (222)
RS4500.337	80 (552)	½ (13)	60 (267)	50 (345)	½ (13)	60 (267)

The mechanical strength ratings in Table 7 are minimum values. The helix diameter, grade, and thickness along with the shaft series to which an individual helix is connected effect the mechanical strength rating of a helix. A higher mechanical strength rating of an individual helix is possible depending on the combination of these variables.

CHANCE[®] HELICAL 2⁷/₈" DIAMETER ROUND SHAFT PRODUCTS (TYPE RS2875.203 SERIES)

COMMON LEAD CONFIGURATIONS

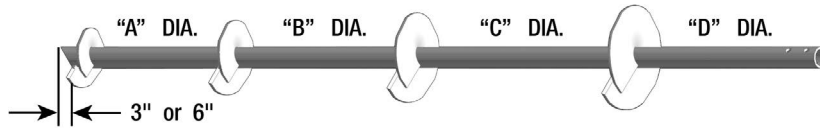

Catalog Number (See Notes Page 24)	Plate Diameter				Nominal Length (ft)	Effective Length (in)*	Weight (lbs)	Helix Grade	Helix Edge**
	A	B	C	D					
CRSLAABFF05	8	10	-	-	5	56.5	45	50	SLE
CRSLAABFF07	8	10	-	-	7	78.3	57	50	SLE
CRSLAABCF05	8	10	12	-	5	56.5	53	50	SLE
CRSLABFFF05	10	-	-	-	5	56.5	40	50	SLE
CRSLABFFF07	10	-	-	-	7	76.3	48	50	SLE
CRSLABCF05	10	12	-	-	5	56.5	53	50	SLE
CRSLABCF07	10	12	-	-	7	76.3	60	50	SLE
CRSLABCDF07	10	12	14	-	7	76.3	78	50	SLE
CRSLABCDF10	10	12	14	-	10	188.3	122	50	SLE
CRSLACFFF05	12	-	-	-	5	56.5	46	50	SLE
CRSLACFFF07	12	-	-	-	7	76.3	54	50	SLE
CRSLADFFF07	14	-	-	-	7	76.3	57	50	SLE
CRSLADFFF10	14	-	-	-	10	118.3	100	50	SLE

*Effective length: from leading edge of bottom helix to center of bolt hole.

**SLE = Sharpened Leading Edge

COMMON EXTENSION CONFIGURATIONS

EXTENSION WITH HELICAL PLATE

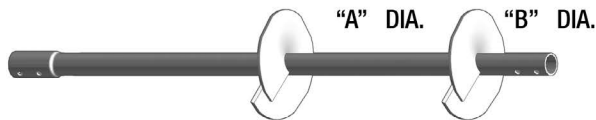

PLAIN EXTENSION



Catalog Number (See Notes Page 24)	Plate Diameter			Nominal Length (ft)	Effective Length (in)*	Weight (lbs)	Helix Grade	Helix Edge**
	A	B	C					
CRSEAFF03CU	-	-	-	3.5	36.0	19	---	---
CRSEAFF05CU	-	-	-	5	57.0	32	---	---
CRSEAFF07CU	-	-	-	7'	78.3	42	---	---
CRSEAFF10CU	-	-	-	10	120	64	---	---
CRSEADFF07CU	14	14	-	7	78.0	75	50	SLE
CRSEADFF05CU	14	-	-	5	57.0	70	50	SLE

* Effective length: from bolt hole to bolt hole.

**SLE = Sharpened Leading Edge



CHANCE® HELICAL 2 7/8" DIAMETER ROUND SHAFT PRODUCTS (TYPE RS2875.276 SERIES)

COMMON LEAD CONFIGURATIONS

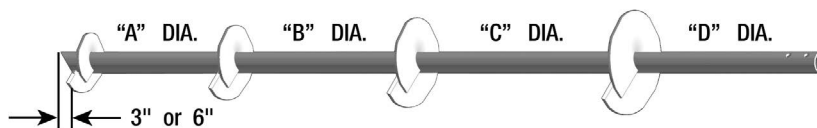

Catalog Number (See Notes Page 24)	Plate Diameter				Nominal Length (ft)	Effective Length (in)*	Weight (lbs)	Helix Grade	Helix Edge**
	A	B	C	D					
CRSLBFFF07	10	-	-	-	7	76.3	68	80	SLE
CRSLBFFF05	10	-	-	-	5	56.3	53	80	SLE
CRSLBCCFF05	10	12	-	-	5	56.3	62	80	SLE
CRSLBABCFF07	8	10	12	-	7	76.3	80	80	SLE
CRSLBBCDF07	10	12	14	-	7	76.3	92	80	SLE
CRSLBABCD10	8	10	12	14	10	118.3	123	80	SLE
CRSLBABFF05	8	10	-	-	5	56.3	56	80	SLE
CRSLBCCFF07	10	12	-	-	7	76.3	71	80	SLE
CRSLBBCDD10	10	12	14	14	10	118.3	135	80	SLE

*Effective length: from leading edge of bottom helix to center of bolt hole.

**SLE = Sharpened Leading Edge

Round Shaft

COMMON EXTENSION CONFIGURATIONS

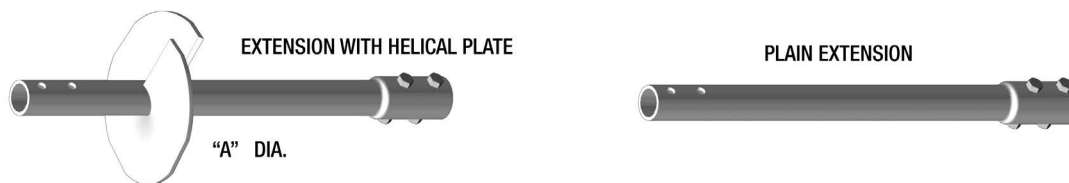

Catalog Number (See Notes Page 24)	Plate Diameter			Nominal Length (ft)	Effective Length (in)*	Weight (lbs)	Helix Grade	Helix Edge**
	A	B	C					
CRSEBFFF03CU	-	-	-	3	36.0	37	---	---
CRSEBFFF05CU	-	-	-	5	57.0	52	---	---
CRSEBFFF07CU	-	-	-	7	78.0	56	---	---
CRSEBFFF10CU	-	-	-	10	120.0	93	---	---
CRSEBDF03CU	14	-	-	3	36.0	52	50	SLE
CRSEBFF03CU	10	-	-	3	36.0	44	50	SLE

* Effective length: from bolt hole to bolt hole.

**SLE = Sharpened Leading Edge



CHANCE[®] HELICAL 3½" DIAMETER ROUND SHAFT PRODUCTS (TYPE RS3500.300 SERIES)

COMMON LEAD CONFIGURATIONS

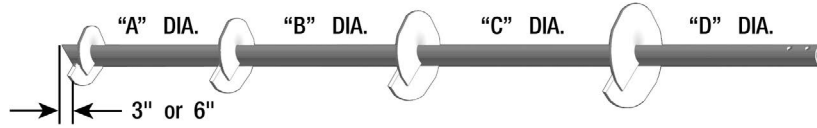

Catalog Number (See Notes Page 24)	Plate Diameter				Nominal Length (ft)	Effective Length (in)*	Weight (lbs)	Helix Grade	Helix Edge**
	A	B	C	D					
CRSLCABFF03	8T	10T	-	-	3	33.3	6	50	BLE
CRSLCABCD10	8T	10T	12T	14T	10	117.3	145	50	BLE
CRSLCABCF07	8T	10T	12T	-	7	74.5	73	50	BLE
CRSLCBBFF07	10T	10T	-	-	7	74.5	78	50	BLE
CRSLCBCFF07	10T	12T	-	-	7	74.5	91	50	BLE
CRSLCBCFF05	10T	12T	-	-	5	41.3	65	50	BLE
CRSLCBCFF10	10T	12T	-	-	10	117.3	121	50	BLE
CRSLCBCDF07	10T	12T	14T	-	7	74.5	106	50	BLE
CRSLCBCDD10	10T	12T	14T	14T	10	117.3	164	50	BLE
CRSLCCDF05	12T	14T	-	-	5	41.3	73	50	BLE
CRSLCCDF10	12T	14T	14T	-	10	117.3	158	50	BLE
CRSLCCDD10	12T	14T	14T	14T	10	117.3	105	50	BLE

*Effective length: from leading edge of bottom helix to center of bolt hole.

**BLE = Blunt Leading Edge

COMMON EXTENSION CONFIGURATIONS

EXTENSION WITH HELICAL PLATE



PLAIN EXTENSION



Catalog Number (See Notes Page 24)	Plate Diameter			Nominal Length (ft)	Effective Length (in)*	Weight (lbs)	Helix Grade	Helix Edge**
	A	B	C					
CRSEFFFF03CU	-	-	-	3	33.3	50	-	-
CRSEFFFF05CU	-	-	-	5	56.0	60	---	—
CRSEFFFF07CU	-	-	-	7	77.0	77	---	—
CRSEFFFF10CU	-	-	-	10	119.0	115	---	—
CRSECCDF07CU	12T	14T	-	7	77.0	105	50	BLE
CRSECDF03CU	14T	-	-	3	43.5	72	50	BLE
CRSECDF07CU	14T	14T	-	7	77.0	114	50	BLE
CRSECDDDF10CU	14T	14T	14T	10	119.0	173	50	BLE

* Effective length: from bolt hole to bolt hole.

"T" after plate diameter means ½" thick helix.

**BLE = Blunt Leading Edge



Round Shaft

CHANCE® HELICAL 4½" DIAMETER ROUND SHAFT PRODUCTS (TYPE RS4500.337 SERIES)

COMMON LEAD CONFIGURATIONS

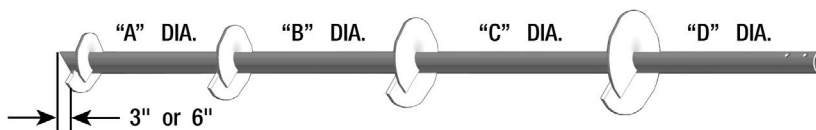

Catalog Number (See Notes Page 24)	Plate Diameter				Nominal Length (ft)	Effective Length (in)*	Weight (lbs)	Helix Grade	Helix Edge**
	A	B	C	D					
CRSLDAFFF07	8T	-	-	-	7	74.5	112	80	SLE
CRSLDAFFF10	8T	-	-	-	10	115.5	169.5	80	SLE
CRSLDAAFF10	8T	8T	-	-	10	115.5	171.5	80	SLE
CRSLDABCF07	8T	10T	12T	-	7	74.5	136	80	SLE
CRSLDABBF07	8T	10T	10T	-	7	74.5	134	80	SLE
CRSLDABCD10	8T	10T	12T	14T	10	115.5	208	80	SLE
CRSLDBCDD10	10T	12T	14T	14T	10	115.5	220	80	SLE
CRSLDBCDF10	10T	12T	14T	-	10	115.5	200	80	SLE
CRSLDDFFF10	14T	-	-	-	10	74.5	177	80	SLE

*Effective length: from leading edge of bottom helix to center of bolt hole.

**SLE = Sharpened Leading Edge

COMMON EXTENSION CONFIGURATIONS

EXTENSION WITH HELICAL PLATE



PLAIN EXTENSION



Catalog Number (See Notes Page 24)	Plate Diameter				Nominal Length (ft)	Effective Length (in)*	Weight (lbs)	Helix Grade	Helix Edge**
	A	B	C	D					
CRSEDFFFF03CU	-	-	-	-	3.5	36.0	53	---	---
CRSEDFFFF05CU	-	-	-	-	5	57.0	78	---	---
CRSEDFFFF07CU	-	-	-	-	7	78.0	105	---	---
CRSEDFFFF10CU	-	-	-	-	10	120.0	158	---	---
CRSEDBCDD10CU	10T	12T	14T	14T	10	120.0	219	80	SLE
CRSEDCCDF07CU	12T	12T	14T	-	7	78.0	150	80	SLE
CRSEDDFFF05CU	14T	-	-	-	5	57.0	97	80	SLE
CRSEDDFFF07CU	14T	-	-	-	7	78.0	124	80	SLE

* Effective length: from bolt hole to bolt hole.

"T" after plate diameter means ½" thick helix.

**SLE = Sharpened Leading Edge

CHANCE® HELICAL 6⁵/₈" DIAMETER ROUND SHAFT PRODUCTS (TYPE RS6625.280 SERIES)

COMMON LEAD CONFIGURATIONS

EXTENSION WITH HELICAL PLATE

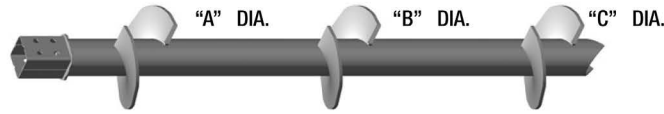

Catalog Number	Description	Plate Diameter				Nominal Length (ft)	Weight	Helix Grade	Helix Edge**	Coating
		A	B	C	D					
CRSLECF07	ANCHOR, LEAD, LDPP (1) 12" x 7', 6" PIPE	12	-	-	-	7	141	80	SLE	GALV
CRSLEDF15	ANCHOR, LEAD, LDPP (1) 14" x 15', 6" PIPE	14	-	-	-	15	297	80	SLE	GALV
CRSLEEF10	ANCHOR, LEAD, LDPP (1) 16" x 10', 6" PIPE	16	-	-	-	10	240	80	SLE	GALV
C3031521	ANCHOR, INSTALLING TOOL, LDPP, 6"	-	-	-	-			---	---	PAINTED

* Effective length: from bolt hole to end of shaft.

**SLE = Sharpened Leading Edge

COMMON EXTENSION CONFIGURATIONS

PLAIN EXTENSION



Catalog Number	Description	Plate Diameter				Nominal Length (ft)	Weight	Coating
		A	B	C	D			
CRSEFFF05	ANCHOR, EXT, LDPP, 5', 6" PIPE, GALV	-	-	-	-	5	95	GALV
CRSEFFF07	ANCHOR, EXT, LDPP, 7', 6" PIPE, GALV	-	-	-	-	7	132.9	GALV
CRSEFFF10	ANCHOR, EXT, LDPP, 10' x 6" PIPE, GALV	-	-	-	-	10	245	GALV

* Effective length: from bolt hole to bolt hole.

CHANCE® HELICAL 8⁵/₈" DIAMETER ROUND SHAFT PRODUCTS (TYPE RS8625.250 SERIES)

COMMON LEAD CONFIGURATIONS EXTENSION WITH HELICAL PLATE

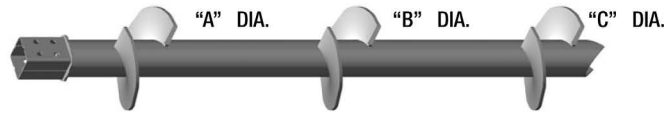

Catalog Number	Description	Plate Diameter				Nominal Length (ft)	Weight	Helix Grade	Helix Edge**	Coating
		A	B	C	D					
CRSLFDFFF07	ANCHOR, LEAD, LDPP (1) 14" x 7', 8" PIPE	14	-	-	-	7	167	80	SLE	GALV
CRSLFEFFF15	ANCHOR, LEAD, LDPP (1) 16" x 15', 8" PIPE	16	-	-	-	15	356	80	SLE	GALV
CRSLFEEEF10	ANCHOR, LEAD, LDPP (3) 16" x 10', 8" PIPE	16	16	16	-	10	255	80	SLE	GALV
CRSLFBCDF10	LEAD, RS8625.250, 10,12,14 10ft LONG	10	12	14	-	10	230	80	SLE	GALV
CRSLFBCDF15	LEAD, RS8625.250, 10,12,14 15ft LONG	10	12	14	-	15	320	80	SLE	GALV
CRSLFCDF10	LEAD, RS8625.250, 12, 14, 10ft LONG	12	14	-	-	10	220	80	SLE	GALV
CRSLFEEEF10	LEAD, RS8625.250, 16,16 10ft LONG	16	16	-	-	10	245	80	SLE	GALV

* Effective length: from bolt hole to end of shaft.

**SLE = Sharpened Leading Edge

CHANCE® HELICAL 8⁵/₈" DIAMETER ROUND SHAFT PRODUCTS (TYPE RS8625.250 SERIES)

COMMON EXTENSION CONFIGURATIONS

PLAIN EXTENSION



Catalog Number	Description	Plate Diameter				Nominal Length (ft)	Weight	Helix Grade	Helix Edge**	Coating
		A	B	C	D					
CRSEFEFFF10	ANCHOR, EXT, LDPP (1) 16" x 10', 8" PIPE	16	-	-	-	10	233	80	SLE	GALV
CRSEFEFFF10	ANCHOR, EXT, LDPP 10', 8" PIPE, GALV	16	16	-	-	10	369	80	SLE	GALV
CRSEFFFFF20	ANCHOR, EXT, LDPP 20', 8" PIPE GALV	-	-	-	-	20	448	---	---	GALV
CRSEFFFFF05	ANCHOR, EXT, LDPP 5', 8" PIPE, GALV	-	-	-	-	5	117	---	---	GALV
CRSEFFFFF07	ANCHOR, EXT, LDPP 7', 8" PIPE, GALV	-	-	-	-	7	157	---	---	GALV
C3031508	ANCHOR, INSTALLING TOOL, LDPP 8"	-	-	-	-		96	---	---	PAINTED

* Effective length: from bolt hole to bolt hole.

**SLE = Sharpened Leading Edge

NOTES: 2⁷/₈" to 8⁵/₈" OD ROUND (PIPE) SHAFT PRODUCTS

1. Included Connection Hardware:

RS2875.203 2⁷/₈" Diameter Material: (2) 3/4" x 4¹/₄" bolt per SAE J429 Grade 5 and nuts.

RS2875.276 2⁷/₈" Diameter Material: (2) 3/4" x 4¹/₄" bolt per SAE J429 Grade 5 and nuts.

RS3500.300 3¹/₂" Diameter Material: (3) 3/4" x 5³/₄" bolt per SAE J429 Grade 5 and nuts.

RS4500.337 4¹/₂" Diameter Material: (2) 1" x 5¹/₂" bolt per SAE J429 Grade 8 and nuts.

RS6625.280 6" Diameter Material: (4) 1" x 8" Threaded Stud and nuts.

RS8625.250 8" Diameter Material: (4) 1¹/₄" x 10¹/₂" Threaded Stud and nuts.

2. The letter "T" after the helix diameter stands for 1/2" thick helix material.
3. All helices are spaced 3 times the diameter of the preceding helix unless otherwise specified by the Customer.
4. All products are Hot Dip Galvanize per ASTM A153.

Round Shaft



CHANCE® HELICAL SQUARE AND ROUND SHAFT COMBINATIONS

TYPE SS/RS COMBINATION HELICAL PILES

CHANCE® Helical Transition Coupler

Adapts Type SS to Type RS Pile Shafts

The type SS/RS combination Pile is used mainly in compression applications in areas where soft/loose soils are located above the bearing strata (hard/dense soils) for the helices. The type RS material with its much greater section modulus will resist columnar buckling in the soft/loose soil. Its larger shaft diameter also provides for lateral load resistance. Due to its slender size, the type SS material provides the means for the helix plates to penetrate deeper into hard/dense soil stratum than if the helical pile shaft was pipe shaft only. For a given helix con guration and same available installation energy (i.e. machine), a small displacement shaft will penetrate farther into a soil bearing strata than a large displacement shaft and will disturb less soil.

It is recommended that a CHANCE SS/RS Combination helical Pile be used in all projects where pipe shaft is being used. The square shaft lead section will provide better load capacity and less settlement than a comparable straight pipe shaft pile.

The transition section (see image) adapts type SS helical lead sections to type RS plain extensions. Installation of this combination pile is the same as a standard helical pile.

Transition Couplers

Table 8

Catalog Number	Description	Torque Ratings
C1071639	SS5/150 square shaft to a RS2875.276 dia round shaft	7,000 ft-lbs
C1071515	SS175 square shaft to a RS3500.300 dia round shaft	10,500 ft-lbs
C1072502	SS200 square shaft to a RS3500.500 dia round shaft	13,000 ft-lbs
C1101443	SS200 square shaft to a RS4500.300 dia round shaft	16,000 ft-lbs
C1101418	SS225 square shaft to a RS4500.300 dia round shaft	21,000 ft-lbs



**Transition Coupler
Figure 5**

SS/RS Combos

ASSEMBLIES AND HARDWARE

ACCESSORIES AND TERMINATION DEVICES FOR CHANCE® HELICAL ANCHORS/PILES

Specifying exactly what you need is easy with CHANCE® Helical Foundation Support Products. CHANCE® offers a variety of standard accessories and special termination devices depending on the project and application. This section illustrates some of our standard termination devices along with their mechanical ratings. If your project requires a special termination device, please contact factory.

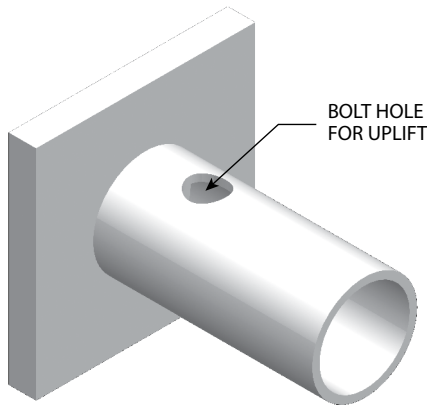

New Construction Pile Cap for Compression and Uplift

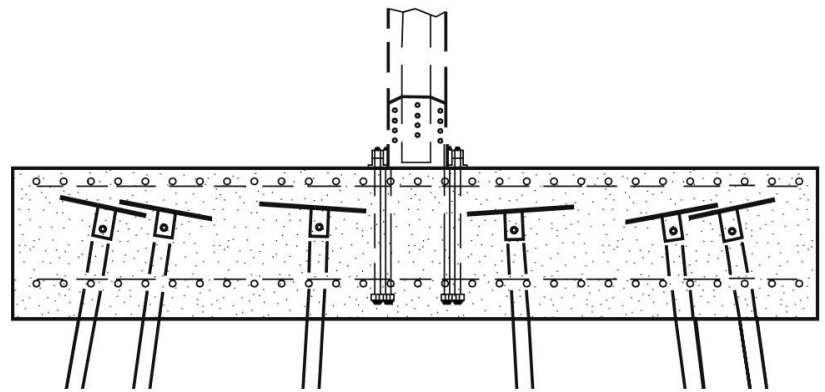

CHANCE® Helical New Construction Pile Caps

Catalog Number	Fits Shaft Size	Plate Dimensions (inches)		Number of Holes	Galvanized	Working Rating (kip)	
		Length	Width			Compression	Tension
C1100904	1.50" square shaft	7	7	1	No	70	46
C1100905	1.75" square shaft	8	8	1	No	110	74
C1100906	2.00" square shaft	12	12	1	No	150	130
C1100907	2.25" square shaft	12	12	1	No	200	92
C1100904G	1.50" square shaft	7	7	1	Yes	70	46
C1100905G	1.75" square shaft	8	8	1	Yes	110	74
C1100906G	2.00" square shaft	12	12	1	Yes	150	130
C1100907G	2.25" square shaft	12	12	1	Yes	200	92
C1100887	2.875" pipe shaft	7	7	2	No	72	72
C1100888	3.5" pipe shaft	10	10	3	No	120	120
C1100889	4.5" pipe shaft	12	12	2	No	130	130
C1100887G	2.875" pipe shaft	7	7	2	Yes	72	72
C1100888G	3.5" pipe shaft	10	10	3	Yes	120	120
C1100889G	4.5" pipe shaft	12	12	2	Yes	130	130

Hardware



ASSEMBLIES AND HARDWARE
TRANSMISSION STRUCTURE FOUNDATION GRILLAGES
FOR CHANCE® HELICAL PILES

Grillages are used to attach helical piles to structure bases or tower legs. Grillages can be designed to fit various possible combinations of piles and structure designs. Please contact factory for additional information about specific projects.

Features & Benefits

- Pre-engineered, power-installed
- Lower project costs
- No advance site preparation, excavation or concrete required
- Install and set tower in all types of weather
- Removes the need to excavate the soil
- Eliminates the need for expensive casings used with drilled shafts
- Grillage assembly available for 3-12 helical piles
- Non-shrink grout to fill void between helical pile and grillage hollow structural steel
- Grillage intended to be used with 3.5" and 4.5" diameter helical pipe piles.



Part Number	Description	Moment Capacity	Piles/Structure
T1101775	GRILLAGE – 4 PILE	0-300 ft-kip	4
C1101943	GRILLAGE – 6 PILE	300-500 ft-kip	6
C1102041	GRILLAGE – 8 PILE	500-800 ft-kip	8
C1102017	GRILLAGE – 8 PILE	800-1,000 ft-kip	8
C1102075	GRILLAGE – 12 PILE	1,500 ft-kip	12
C1102076	GRILLAGE – 12 PILE	1,900 ft-kip	12

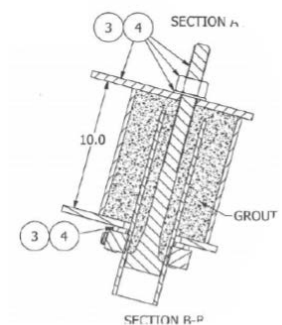
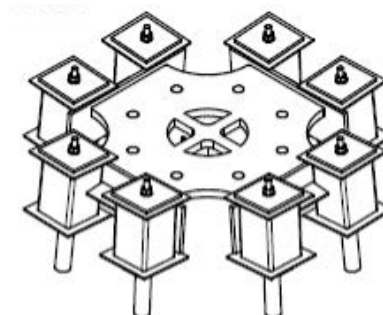
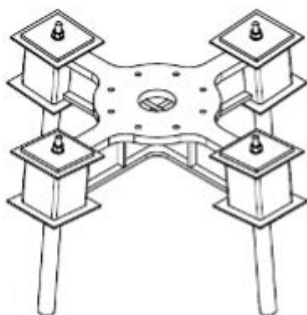

Hardware

INSTALLATION TOOLS

INSTALLING TOOLS FOR HELICAL ANCHORS AND PILES

WARNING

Do not weld, cut, alter or modify any of the equipment shown in this Bulletin. Doing so will void all warranties and could create hazardous conditions for anyone in the vicinity of the equipment when in use.

Portable Anchor Installers for Small Foundations and Anchors

2,500 ft.-lb. torque capacity hydraulic power drive

Economical manual operation and portability for remote sites, common anchor installations

For most shaft-driven guy anchors and smaller screw foundations, these compact drivers get into areas where large equipment cannot go or is impractical. Operator does not need to resist the torque generated by anchor installation. Counter torque transmits through a torque bar from the drive head to the earth or other restraint. This frees the operator for the task of guiding the anchor path.

Built-in bypass valve limits output to 2,500-ft.-lb. maximum, two-way foot pedal gives operator direct control over drive and reverse directions, hoses (two 12-ft. and two 25-ft.) come with quick couplers for all connections from power supply to foot control to drive head. Pivoting drive-head yoke connects with bent-arm pin to square-tubular torque bar which telescopes from 8 feet to 10 feet as needed.

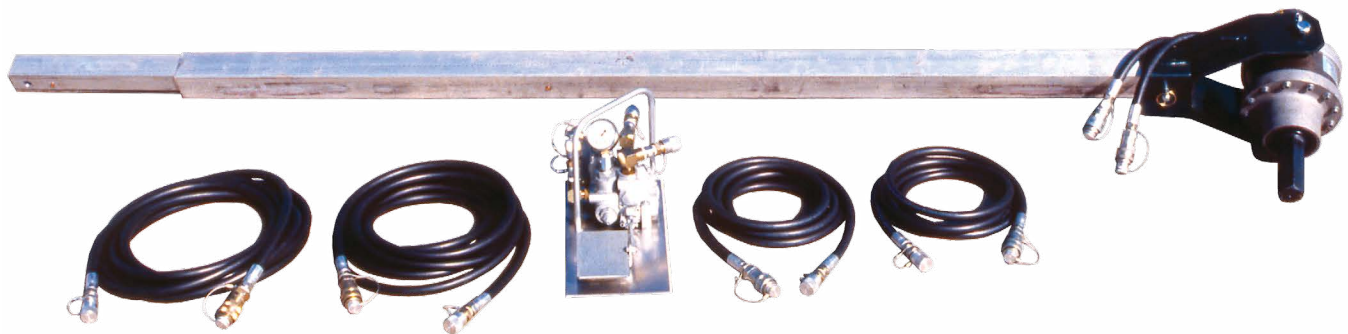

Catalog Number C3031244

Heavy-Duty Installer requires 1900 psi at 8 gpm flow rate to deliver 2,500 ft.-lb. maximum torque.

2,500 FT-LB PORTABLE ANCHOR INSTALLERS ORDERING INFORMATION

Heavy Duty — Catalog Number C3031244

Sealed oil-filled gear case.

Single Catalog Number above includes all items below.

Each item also may be ordered by separate number.

*Hydraulic Control Valve	C3031247
Two 25-ft. Hydraulic Hoses	C4176121 (each)
*Hydraulic Drive Head	C3031233
Yoke Assembly	E3030680
*Two 12-ft. Hydraulic Hoses	E3031253 (pair)
Square Torque Bar Assembly	E3031041

Output shaft is 2" Hex. – Requires Kelly Bar Adapter P630013 and flanged drive tool (order separately) to install all anchors.

* Note: Hydraulic components are not interchangeable between C3031032 and C3031244.

Optional Hydraulic Power Unit

Catalog Number C3031201

For easy wheeling to worksite, hydraulic drive head and foot control secure by rubber strap included to angle braces atop the cart frame and hoses ride on handles.

Cart-mounted on 5/8" -diameter axle with two 4.80 x 8 inflatable (30psi) tires; 27 1/4" wide x 34 1/2" high x 36" long; shipping weight with oil: 275 lb.

Hydraulic Pump with fan cooling system:

Typical output pressure 2500psi
 Pump displacement 8 gpm @ 3400rpm
 Reservoir capacity 5 gallons US
 (shipping cap and vented fill cap provided)

Gasoline Engine System:

16hp Briggs & Stratton
 Industrial/Commercial Model 326437, Type 2527
 12-Volt pushbutton start, 3600rpm (maximum)

Operating instructions are included with anchor installer and hydraulic power unit.



Drive head and foot control shown in photo are not included with C3031201

ANCHOR DRIVE TOOLS

SS Helical Pier Anchors Drive Tools

These tools include our proprietary Alignment Window that helps reduce chance of finger pinch when anchor is inserted into tool. Alignment Window also makes it faster and easier to line up the anchor and anchor tool.

These drive tools require the appropriate Kelly bar adapter, sold separately. Each comes with bolts, nuts and lockwashers.

Catalog Number	SS Anchor Series Tool	Bolt Circle, Holes	Approx. Weight (lbs)
639001	SS5/SS150	5¼", (6) ½" holes	7
C3030195*	SS175	7⅝", (12) ⅝" holes	18
C3030201*	SS200	7⅝", (12) ⅝" holes	30
C3030202*	SS225	7⅝", (12) ⅝" holes	30

*Coupling to a Kelly bar adapter with a 5¼" bolt circle requires use of T3030166 adapter and limits tool's maximum torque rating to 10,000 ft.-lb.

These tools slide into locking dog adapter and are retained by spring loaded dogs.

Catalog Number	Description	Unit fits:	Approx. Weight (lbs)
C3030020	SS5/SS150/RR Drive Tool	STANDARD Locking Dog Assembly	8
C3031035		TOUGH ONE® Locking Dog Assembly	11
T3031403	SS175 Drive Tool	TOUGH ONE® Locking Dog Assembly	26
C3031077	SS200 Drive Tool		23

Each of these drive tools includes an integral set of locking dogs that attach the drive tool to the anchor. There is no need to use bent arm pin and coil lock to attach these tools to an anchor.

These drive tools require the appropriate Kelly bar adapter, sold separately. Each comes with bolts, nuts and lockwashers.

Catalog Number	SS Anchor Series Tool	Bolt Circle, Holes	Approx. Weight (lbs)
C3031650	SS5/SS150	5¼", (6) ½" holes	10
C3031645	SS175	7⅝", (12) ⅝" holes	21

RS278 Helical Pile Anchors Drive Tools

Each Drive Tool comes with one set of pins, bolts, nuts and lockwashers.

Catalog Number	Bolt Circle, Holes	Approx. Weight (lbs)
C3031626*	7⅝", (8) ⅝" holes	44
C3031624	RS278.276 two-pin set only	5

*Drive Tool maximum torque rating 13,000 ft.-lb.



639001



C3030020



C3031650

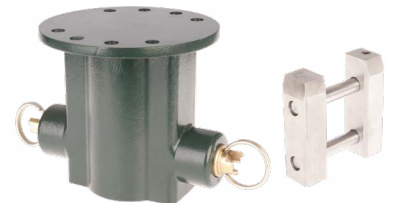

C3031626



C3031624

ANCHOR DRIVE TOOLS

RS3500 Helical Pier Anchors Drive Tools

Each Drive Tool comes with one set of pins, bolts, nuts and lockwashers.

Catalog Number	Bolt Circle, Holes	Approx. Weight (lbs)
C3031627*	7 $\frac{5}{8}$ " , (8) $\frac{5}{8}$ " holes	46
C3031620	RS3500 three-pin set only	6

*Drive Tool maximum torque rating 13,000 ft.-lb.



RS4500 Drive Tool

Each comes with bolts, nuts and lockwashers.

Catalog Number	Bolt Circle, Holes	Approx. Weight (lbs)
C3031546*	7 $\frac{5}{8}$ " , (12) $\frac{5}{8}$ " holes	30

*Maximum torque rating 20,000 ft.-lb.

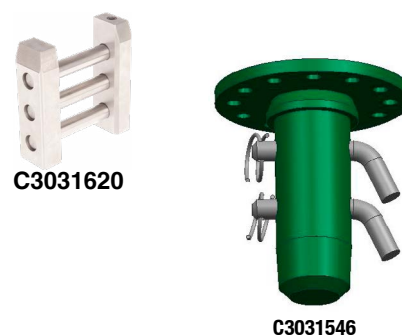

RS6625 and RS8625 Drive Tools

Model	Catalog Number	Bolt Circle, Holes	Approx. Weight (lbs)
RS6625	C3031521	7 $\frac{5}{8}$ " , (12) $\frac{5}{8}$ " holes	90
RS8625	C3031508	7 $\frac{5}{8}$ " , (12) $\frac{5}{8}$ " holes	96

*Maximum torque rating 20,000 ft.-lb.

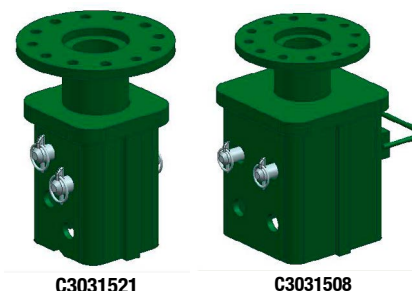

Base Plate Drive Tool

Fits on 10"–Square Base Plate Foundations for *20,000 ft.–lb. Maximum Installing Torque

This tool weighs approx. 60 lbs. and has 12 holes on a 7 $\frac{5}{8}$ " bolt circle, tapped for $\frac{5}{8}$ " bolts furnished with compatible Kelly Bar adapters.

*Coupling to a Kelly Bar adapter with a 5 $\frac{1}{4}$ " bolt circle requires use of T3030166 adapter and limits tool's maximum torque rating to 10,000 ft.-lb.

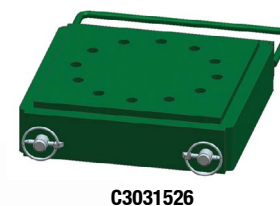

Universal Tools for Base Plate Foundations

These tools fit Foundation Anchors with 9" to 13 $\frac{1}{2}$ " bolt circles.

C3030139 connects direct to a Kelly bar adapter with (6) $\frac{1}{2}$ " furnished bolts.

C3030684 includes (12) $\frac{5}{8}$ " bolts.

Catalog Number	Bolt Circle, Holes	Approx. Weight (lbs)
C3030139*	5 $\frac{1}{4}$ " , (6) $\frac{1}{2}$ " tapped holes	18
C3030684†	7 $\frac{5}{8}$ " , (6) $\frac{5}{8}$ " drilled holes	49

*Maximum torque rating for C3030139: 10,000 ft.-lb.

†Maximum torque rating for C3030684: 20,000 ft.-lb. Coupling C3030684 to a Kelly bar adapter with a 5 $\frac{1}{4}$ " bolt circle requires use of T3030166 adapter and limits tool's maximum torque rating to 10,000 ft.-lb.





HUBBELL[®] **Power Systems, Inc.**

• 210 N. Allen St. • Centralia, MO 65240 • (573) 682-5521

NOTICE: For the latest revision of our Catalog and Literature, click here or visit our web site: www.hubbellpowersystems.com

NOTE: Hubbell has a policy of continuous product improvement. We reserve the right to change design and specifications without notice. ©Copyright 2023 Hubbell Incorporated

NEVER COMPROMISE™

www.hubbellpowersystems.com

